

6K ATTACHMENT CYLINDERS

These attachment cylinders are designed for demanding applications and offer extended seal life even when work induced loads generate pressure spikes over 15,000 psi.

Design features for extending operating life:

1. Port closing cushion reduced impact at end of retract stroke.
2. Step cut wear rings act as pressure buffers as well as bearings.
3. Step Lock piston seal provides the longest seal life when pressures exceed 7,000 psi.
4. Taper allows for a larger thread diameter by increasing the contact area of piston to eliminate having the piston cold form over the rod.
5. Urethane U-Seal between the head and barrel extend operating life over an O-Ring and back up ring.
6. A Hallite 621 U-Seal with anti extrusion ring provides for excellent rod seal

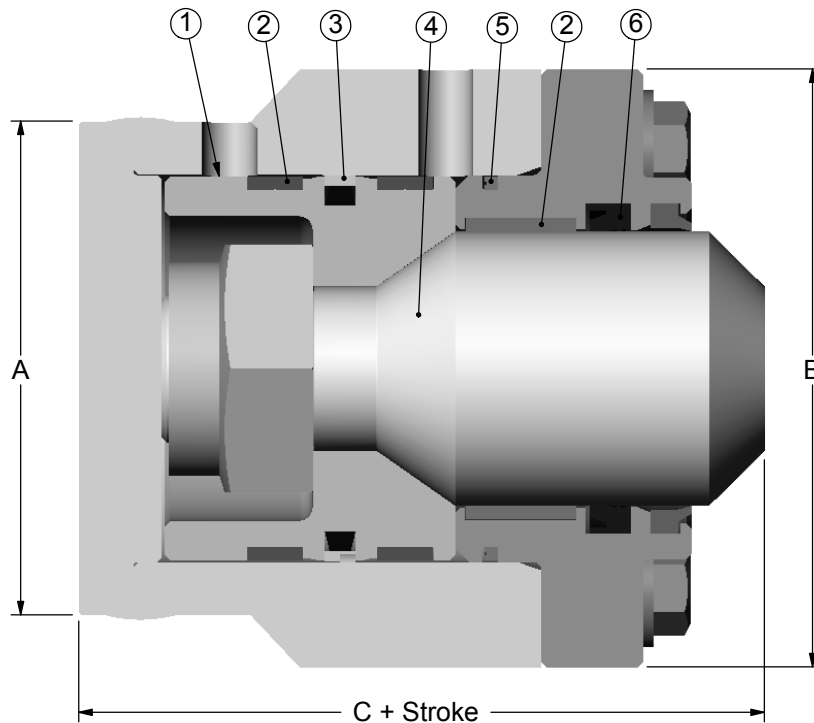

Quick Ship Sizes

Bore Diameter	Rod Diameter	Maximum stroke	Maximum Compressive Force	Maximum Tension Force	A	B	C
3.525	2.500	24"	146,600 lbs	80,000 lbs	4.50"	5.45"	6.25"
4.025	2.500	24"	191,100 lbs	114,000 lbs	5.00"	5.95"	6.25"
5.025	3.000	30"	297,800 lbs	196,700 lbs	6.25"	7.45"	7.13"

Quick ship sizes built to fit your application have short lead times, 3", 4 1/2", 5 1/2", 6", 6 1/2", 7", and 8" bore sizes are available in 4 to 6 weeks. Other sizes can be manufactured per request.

For more information call 360-264-2141.